

Light and Sound

Question paper 2

Level	IGCSE(9-1)
Subject	Physics
Exam Board	Edexcel IGCSE
Module	Double Award (Paper 1P)
Topic	Waves
Sub-Topic	Light and Sound
Booklet	Question paper 2

Time Allowed: 64 minutes

Score: /53

Percentage: /100

Grade Boundaries:

A*	A	B	C	D	E	U
>85%	'75%	70%	60%	55%	50%	<50%

1 A ray of light enters a glass block and is refracted as shown in Figure 1.

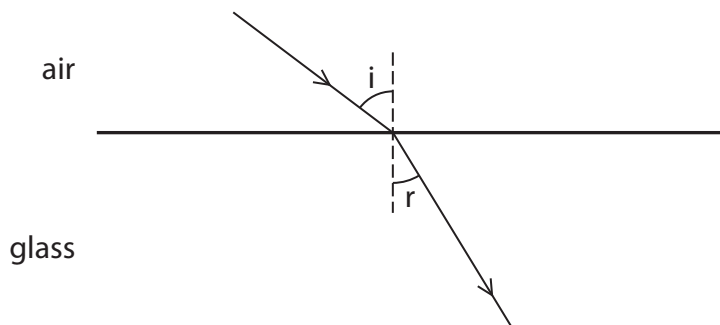

Figure 1

(a) Explain why the ray of light is refracted towards the normal.

(2)

.....

.....

.....

.....

(b) Opals and diamonds are transparent stones used in jewellery.

Jewellers shape the stones so that light is reflected inside.

Figure 2 shows the path of a ray of light that enters and leaves a shaped piece of opal.

This ray of light is totally internally reflected.

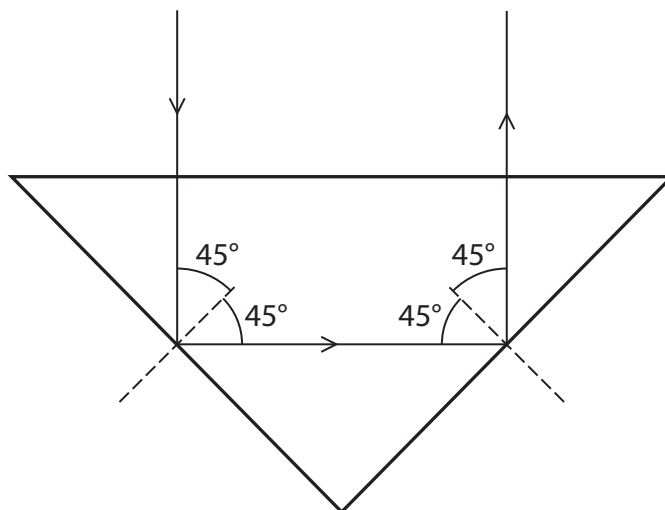

Figure 2

(i) State the equation linking refractive index and critical angle.

(1)

(ii) The critical angle of opal is 43° .

Show that the refractive index of opal is about 1.5.

(2)

(iii) The refractive index of diamond is 2.4.

Explain why rays of light inside a diamond are more likely to be totally internally reflected than those inside an opal.

(3)

.....

.....

.....

.....

.....

.....

.....

.....

.....

.....

.....

(Total for Question 1 = 8 marks)

2 The diagram shows one of two 45° prisms used in an optical instrument.

The second prism is not shown.

The path of a ray of light is partly shown.

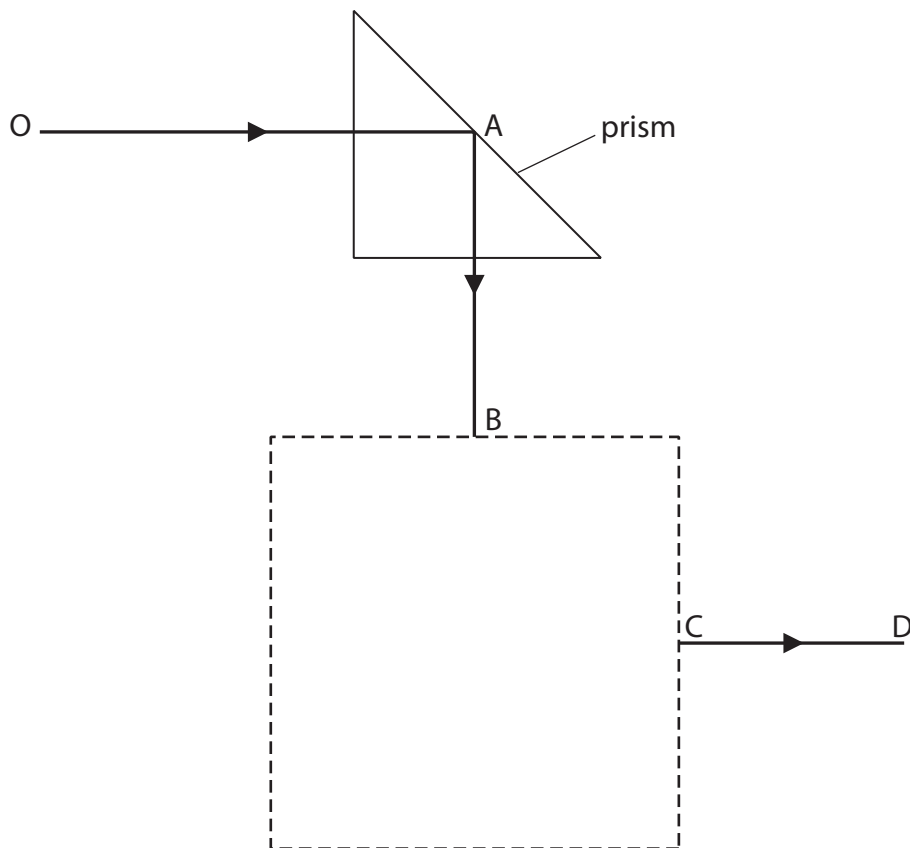

(a) What is the effect shown at point A?

(1)

(b) The ray of light exits from the second prism along the line CD.

(i) Draw the position of the second prism inside the dotted square.

(1)

(ii) Complete the path of the light through the second prism.

(1)

(Total for Question 2 = 3 marks)

3 The diagram shows a light ray passing through a semicircular block of glass.

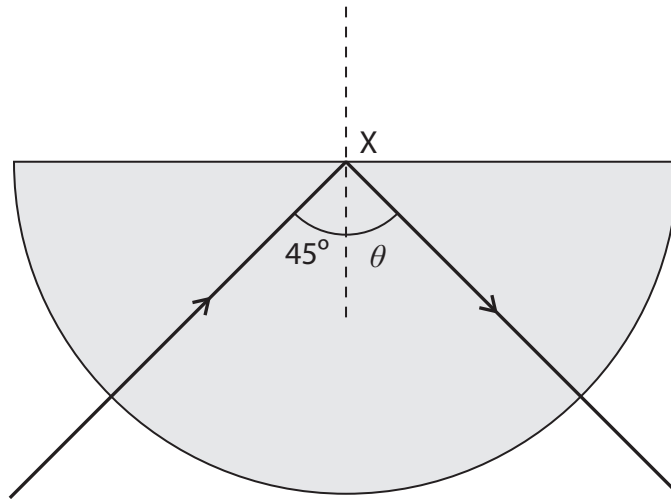

The dotted line is the normal to the surface at X.

When the light ray hits the surface as shown, **all** of it is reflected back inside.

(a) (i) Name the process shown in the diagram.

(2)

(ii) What is the angle labelled θ ?

(1)

(b) The diagram shows another light ray entering a right-angled glass block.

It hits the inside surface at Y as shown.

Add to the diagram to complete the path of the ray.

(3)

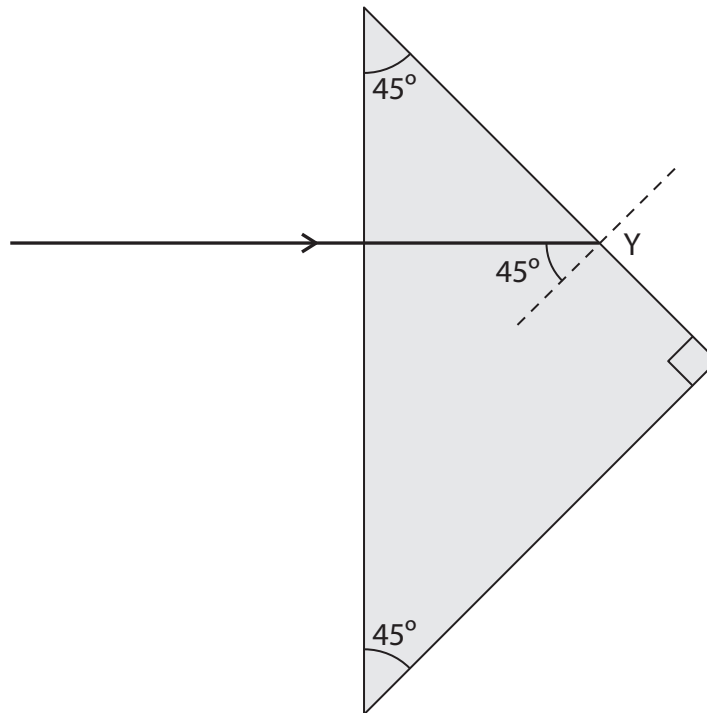

(Total for Question 3 = 6 marks)

(c) The speed of sound in air is different for different heights above sea level.

The graph shows how the speed of sound varies with height.

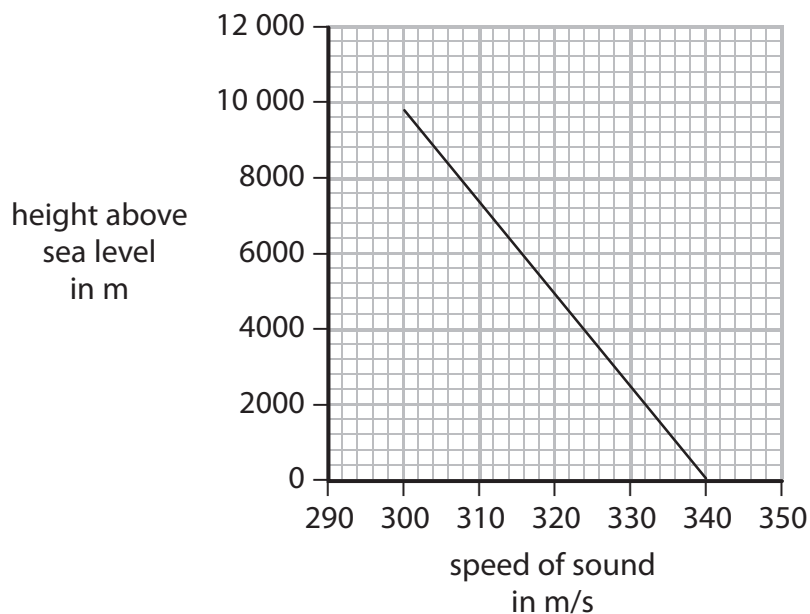

(i) Use the graph to estimate the speed of sound in air 6000 m above sea level. (1)

Speed = m/s

(ii) Describe the pattern shown by the graph. (2)

.....

.....

.....

.....

.....

.....

(iii) Some aeroplanes can travel faster than the speed of sound.

When an aeroplane travels faster than the speed of sound it causes a shock wave. People on the ground hear this shock wave as a sonic boom.

A student says



It is easier for an aeroplane to make a sonic boom when it travels higher up.

Do you agree with the student?

Explain why.

(2)

.....

.....

.....

.....

.....

.....

(Total for Question 4 = 11 marks)

5 (a) Which diagram shows the reflection of a ray of light at a plane mirror?

(1)

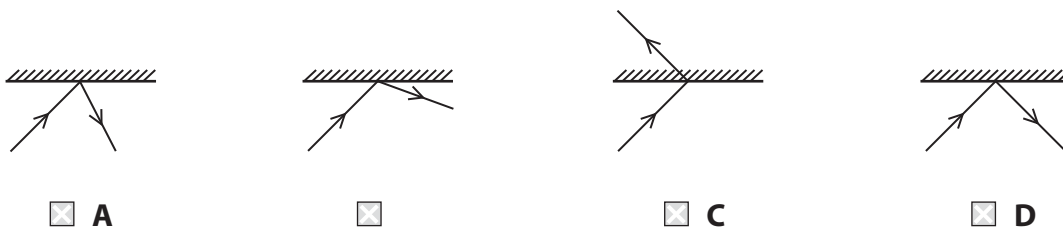

(b) The diagram below shows a ray of light as it passes from air into a glass block.

The angle of incidence is 43° and the light is refracted as shown.

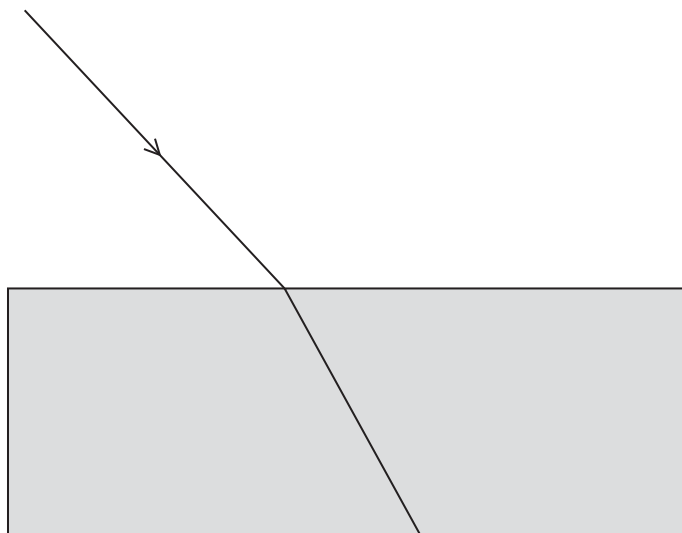

(i) On the diagram, draw the normal for this refraction.

(1)

(ii) On the diagram, mark the angle of refraction.

(1)

(iii) Measure the angle of refraction.

(1)

angle of refraction =^o

(iv) State the relationship between refractive index, angle of incidence and angle of refraction.

(1)

(v) Calculate the refractive index of the glass.

(2)

refractive index =

(c) The diagram shows how light can travel in a glass fibre.

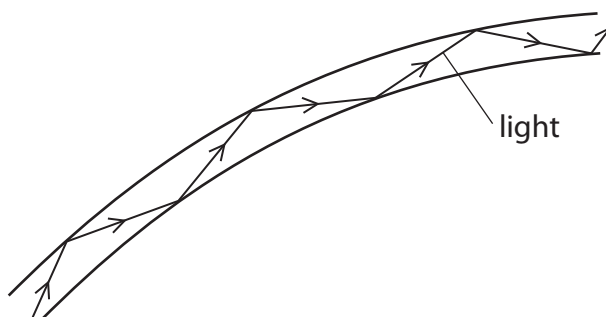

(i) What is the name given to the effect shown?

(1)

.....

(ii) Explain what is happening to the light in the glass fibre.

(3)

.....
.....
.....
.....
.....
.....

(Total for Question 5 = 11 marks)

6 A student plans to measure the refractive index of glass.

She traces a ray of light through a glass block as shown in the diagram.

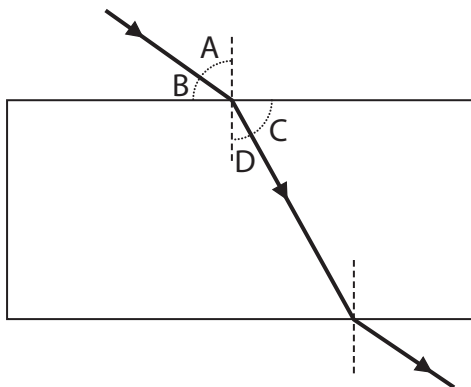

(a) Which letter represents the angle of refraction?

(1)

- A
- B
- C
- D

(b) Explain how the student can use the glass block to find an accurate value for the refractive index of glass.

(4)

.....

.....

.....

.....

.....

.....

.....

.....

.....

.....

.....

.....

.....

.....

.....

.....

.....

.....

.....

.....

.....

.....

(Total for Question 6 = 5 marks)

7 In 1969, astronauts left a reflector on the surface of the Moon.

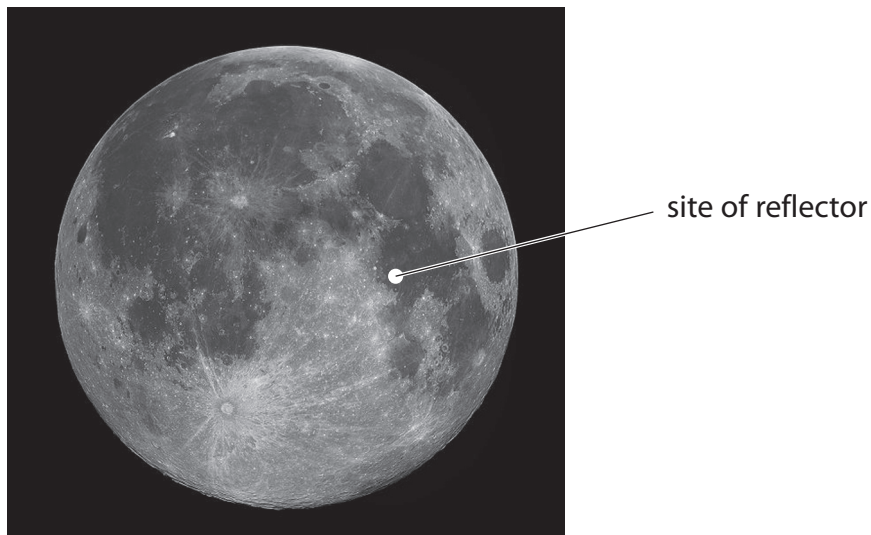

Author: Gregory H. Revera

The reflector consists of mirrors at 90° to each other.

Scientists on Earth aim light from a laser at the reflector.

This light reflects back to them.

(a) The diagram shows two mirrors in the reflector.

Complete the diagram to show the path of the ray of light.

(2)

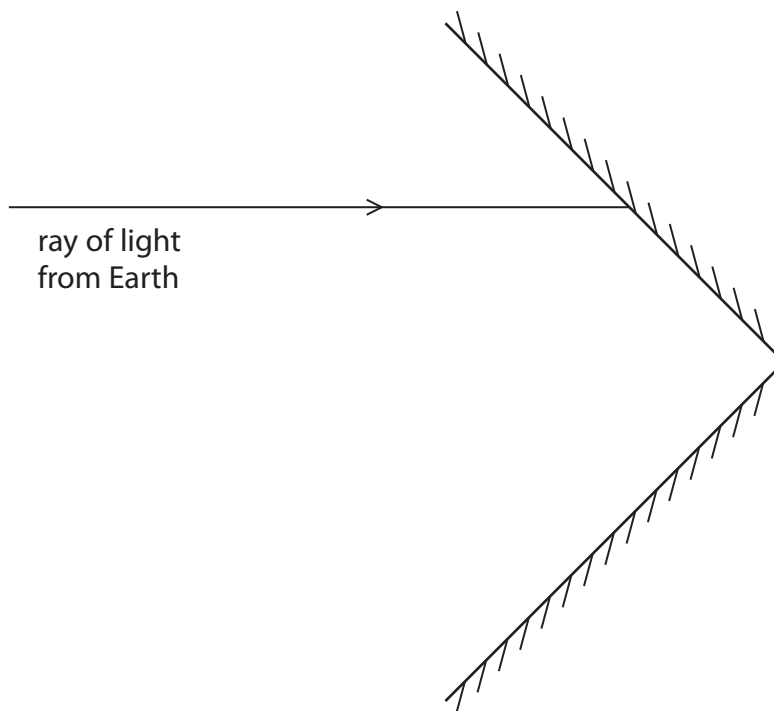

(b) The speed of light in a vacuum is 300 000 km/s.

The average time for a ray of light to travel to the Moon and back is about 2.6 s.

Show that the Moon is about 400 000 km from the Earth.

(3)

(c) Scientists measure the time for the light to travel to the Moon and back very accurately, but the time is different every day.

The graph shows how these times change over the period of one month.

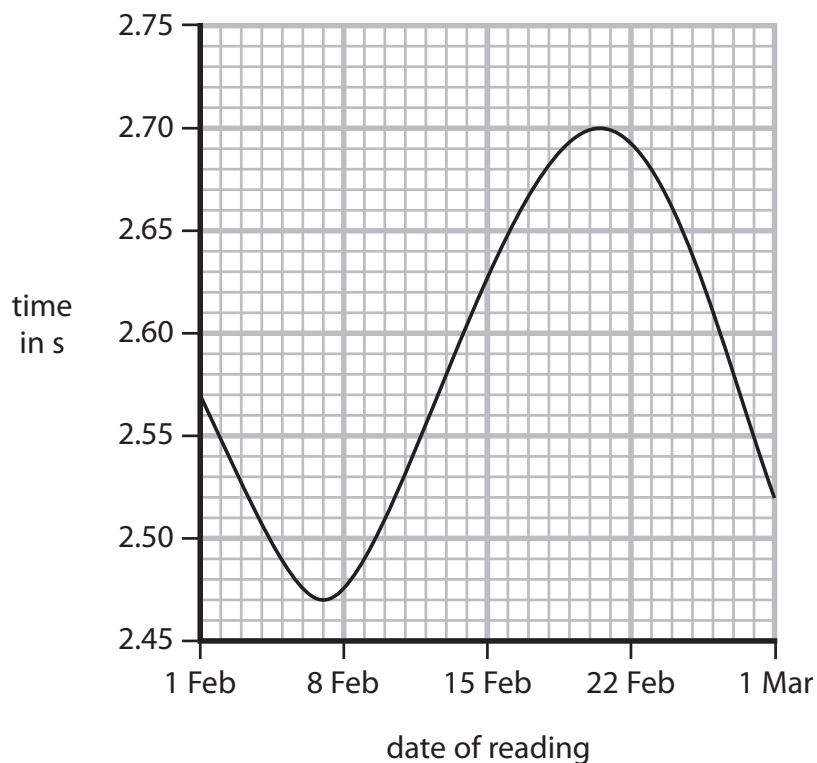

- (i) Suggest what can be deduced about the orbit of the Moon from the information in the graph.

(3)

.....

.....

.....

.....

.....

.....

.....

.....

.....

.....

- (ii) The scientists also discovered that the average time for light to travel to the Moon and back increases gradually every year.

What further information does this give about the orbit of the Moon?

(1)

.....

.....

(Total for Question 7 = 9 marks)