

Energy Transfers

Question paper 1

Level	IGCSE(9-1)
Subject	Physics
Exam Board	Edexcel IGCSE
Module	Double Award (Paper 1P)
Topic	Energy resources and energy transfers
Sub-Topic	Energy Transfers
Booklet	Question paper 1

Time Allowed: 77 minutes

Score: /64

Percentage: /100

Grade Boundaries:

A*	A	B	C	D	E	U
>85%	'75%	70%	60%	55%	50%	<50%

1 The diagram shows a metal device for cooking potatoes.

Potatoes are pushed onto the metal spikes.

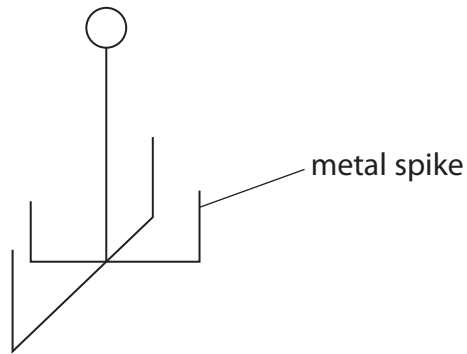

The photograph shows two potatoes cooking in an electric oven.

The inside of the oven is black.

The heating element is at the bottom of the oven.

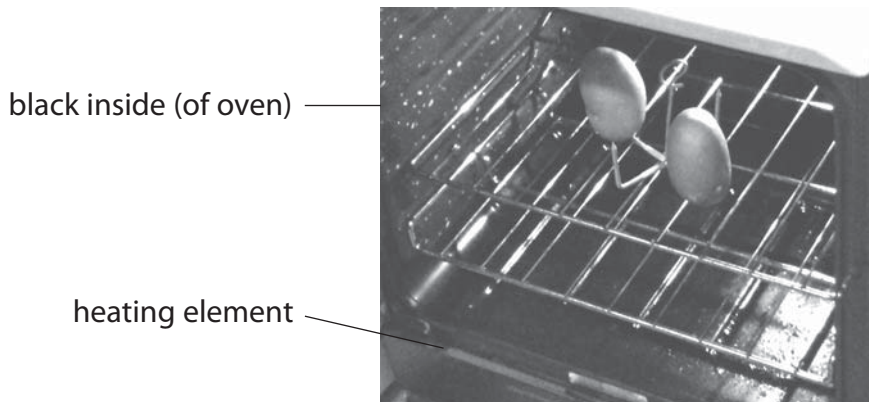

Describe the different ways in which energy is transferred to cook the potatoes.

(6)

.....

.....

.....

.....

.....

.....

.....

.....

.....

.....

.....

.....

.....

.....

.....

.....

.....

.....

.....

.....

.....

.....

.....

(Total for Question 1 = 6 marks)

2 The diagram shows a lighting circuit in a house.

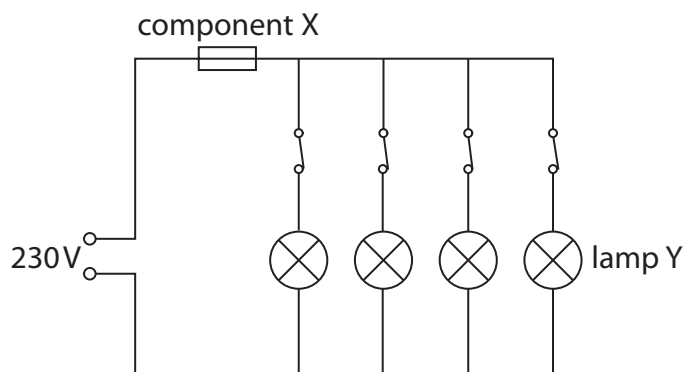

(a) (i) Component X is

(1)

- A a double insulated wire
- B an earth connection
- C a fuse
- D a switch

(ii) The lamps are connected in parallel.

State an advantage of using a parallel circuit for lighting.

(1)

.....

.....

(b) The lighting circuit is connected to a mains supply that provides an alternating current.

Explain what is meant by an alternating current.

You may draw a diagram to help your answer.

(2)

.....

.....

.....

.....

(c) Lamp Y is removed and replaced with a low-energy lamp.

When the low-energy lamp is connected to a 230 V supply, the current in it is 0.12 A.

(i) Calculate the amount of energy transferred by the low-energy lamp in 7 hours.

(3)

energy transferred = J

(ii) The low-energy lamp gives the same amount of light as lamp Y, but uses much less power.

Which row of the table compares the low-energy lamp correctly to lamp Y?

(1)

	Voltage across low-energy lamp compared to voltage across lamp Y	Current in low-energy lamp compared to current in lamp Y
<input type="checkbox"/> A	less than	same as
<input type="checkbox"/> B	same as	less than
<input type="checkbox"/> C	less than	less than
<input type="checkbox"/> D	same as	same as

(Total for Question 2 = 8 marks)

3 The diagram shows part of a lighting circuit in a house.

The circuit is protected by fuse F.

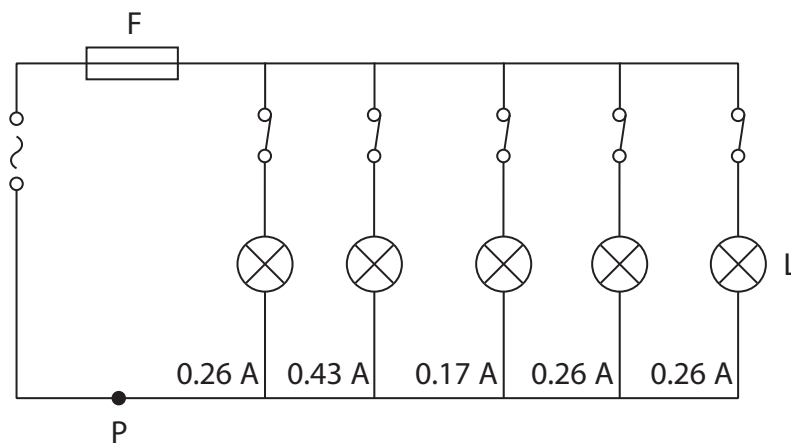

(a) Give two reasons why the lamps are wired in parallel.

(2)

1

.....

.....

2

.....

.....

(b) What is the current at P?

(1)

A 0.17 A

B 0.26 A

C 0.43 A

D 1.38 A

(c) Explain how the fuse protects the circuit.

(3)

.....

.....

.....

.....

.....

.....

(d) (i) State the equation linking power, current and voltage.

(1)

(ii) Calculate the power of lamp L.
[assume the mains voltage is 230 V]

(2)

power = W

(iii) Calculate the amount of energy transferred by lamp L in 3 minutes.

Give the unit.

(3)

energy transferred = unit

(e) This diagram shows another lighting circuit.

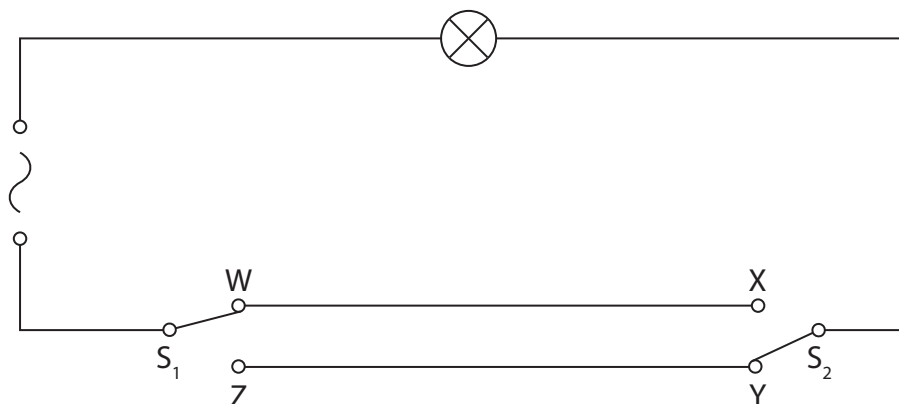

(i) Complete the table by putting a tick (✓) in the box if the lamp is lit and a cross (✗) in the box if the lamp is not lit.

(2)

S_1 position	S_2 position	lamp lit (✓ or ✗)
W	X	
W	Y	
Z	X	
Z	Y	

(ii) Suggest where this circuit would be useful in a house.

(1)

.....

.....

(Total for Question 3 = 15 marks)

4 The diagram shows some electrical appliances.



A

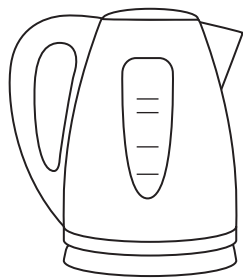

B

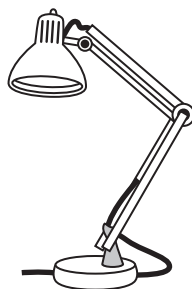

C

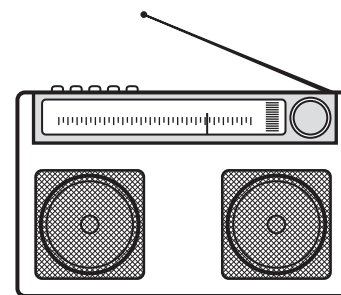

D

(a) (i) Which appliance is designed to transfer electrical energy to thermal energy? (1)

- A food mixer
- B kettle
- C lamp
- D radio

(ii) Which appliance is designed to transfer electrical energy to kinetic energy? (1)

- A food mixer
- B kettle
- C lamp
- D radio

(b) In all the appliances, energy is conserved.

What is meant by the phrase **energy is conserved**? (1)

.....

.....

(c) (i) The lamp has an efficiency of 20%.

Explain what this means.

(2)

.....

.....

.....

.....

(ii) Draw a labelled Sankey diagram for the lamp.

(3)

(Total for Question 4 = 8 marks)

- 5 A student investigates how the surface area of water affects how quickly it cools down. He puts warm water into different shaped containers. The photograph shows two of the containers.



This is the student's plan.

I will use four different containers and work out the surface area of water in each one.

I will heat some water and pour the same volume into each container.

I will put a thermometer into each container and measure the water temperatures.

After 15 minutes I will measure the temperatures again.

- (a) State the independent variable in this investigation. (1)

.....

- (b) (i) State one variable that the student plans to control. (1)

.....

- (ii) Explain why it is important to control this variable. (2)

.....
.....
.....
.....

(c) Suggest a safety precaution for this investigation.

(1)

.....

.....

(d) The table shows the student’s results.

Surface area in cm ²	Starting temperature in °C	Temperature after 15 minutes in °C	Temperature difference in °C
600	85	54	
400	95	55	
300	88	60	
150	85	60	

(i) Complete the table by inserting the missing temperature differences.

(2)

(ii) The student wants to display the data on a graph.

Give suitable labels for the axes of his graph.

(3)

x-axis

y-axis

(iii) The student realises that it was a mistake to have different starting temperatures.

Suggest how he could change his method to correct this mistake.

(2)

.....

.....

.....

.....

.....

.....

.....

(Total for Question 5 = 12 marks)

6 The Moon orbits the Earth.

(a) State a difference between the orbit of a moon and the orbit of a planet.

(2)

.....

.....

.....

.....

(b) The radius of the Moon's orbit is 385 000 km.

It takes 27 days for the Moon to complete one orbit.

Calculate the orbital speed of the Moon.

Give a suitable unit.

(3)

orbital speed = unit

(c) In 1971, astronaut Alan Shepard hit a golf ball on the surface of the Moon.

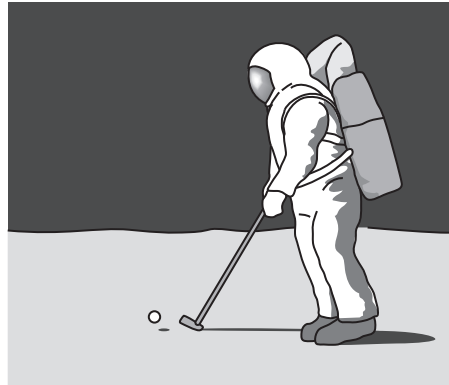

The golf ball had a mass of 50 g and he transferred 56 J of energy to it.

(i) State the equation linking kinetic energy, mass and velocity. (1)

(ii) Calculate the initial velocity of the ball. (3)

initial velocity = m/s

(d) At its highest point the ball had gained 12 J of gravitational potential energy.

(i) State the kinetic energy of the ball at its highest point.

(1)

kinetic energy =J

(ii) State the equation linking gravitational potential energy, mass, g and height.

(1)

(iii) Calculate the maximum height that the ball reached.
(gravitational field strength on the Moon, $g = 1.6 \text{ N/kg}$)

(2)

maximum height =m

(e) Suggest why the ball travelled further on the Moon than it would have done on Earth.

(2)

.....

.....

.....

.....

.....

.....

.....

(Total for Question 6 = 15 marks)