

Energy Transfers

Question paper 2

Level	IGCSE(9-1)
Subject	Physics
Exam Board	Edexcel IGCSE
Module	Double Award (Paper 1P)
Topic	Energy resources and energy transfers
Sub-Topic	Energy Transfers
Booklet	Question paper 2

Time Allowed: 84 minutes

Score: /70

Percentage: /100

Grade Boundaries:

A*	A	B	C	D	E	U
>85%	'75%	70%	60%	55%	50%	<50%

1 (a) The diagram shows a motor lifting a 130 g mass.

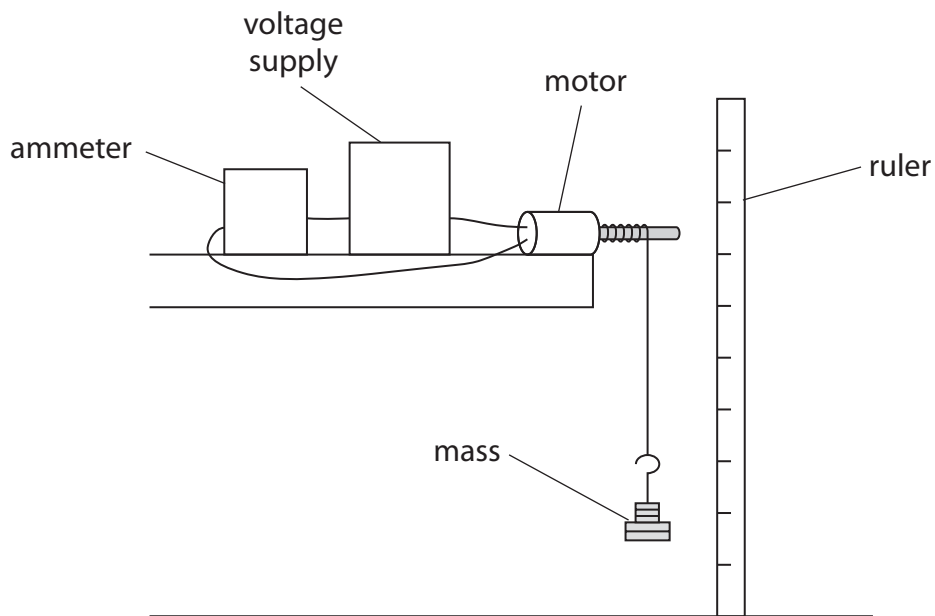

The current in the motor is 2.1 A and the voltage across it is 12 V.

The motor takes 1.5 s to lift the mass.

(i) Calculate the electrical energy transferred to the motor as it lifts the mass.

Give your answer to two significant figures.

(3)

energy = J

(ii) State the equation linking gravitational potential energy, mass, g and height. (1)

(iii) The motor lifts a 130 g mass to a height of 63 cm.

Calculate the gravitational potential energy (GPE) gained by the 130 g mass. (2)

GPE = J

(iv) Why is the amount of GPE gained by the mass less than the amount of electrical energy transferred to the motor? (2)

.....

.....

.....

.....

.....

.....

(b) The diagram shows an electric motor and the direction of current.

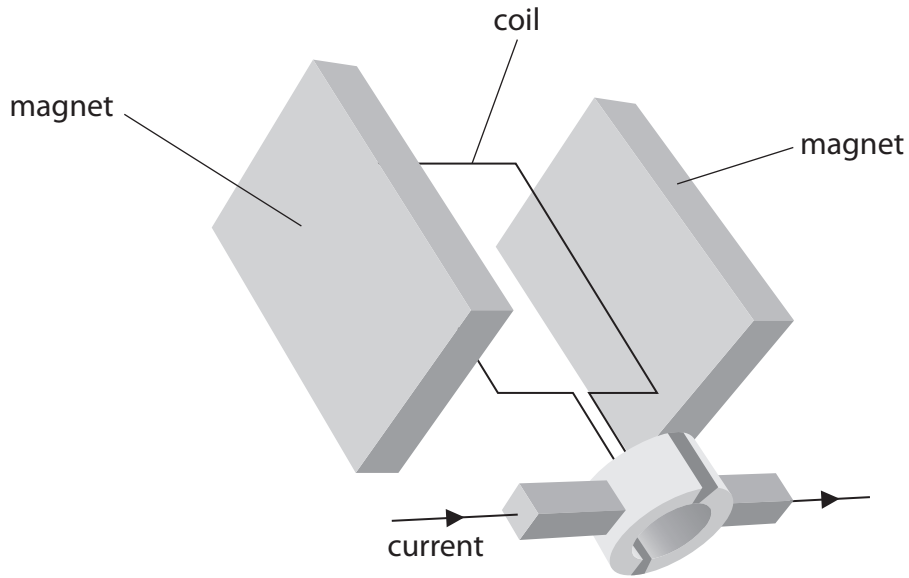

Explain how the current produces movement of the coil.

(4)

.....

.....

.....

.....

.....

.....

.....

.....

.....

.....

.....

.....

.....

.....

.....

.....

.....

.....

.....

.....

.....

(Total for Question 1 = 12 marks)

2 The diagram shows some lamps connected together.

There are 20 small lamps connected in series with a 9 V supply.

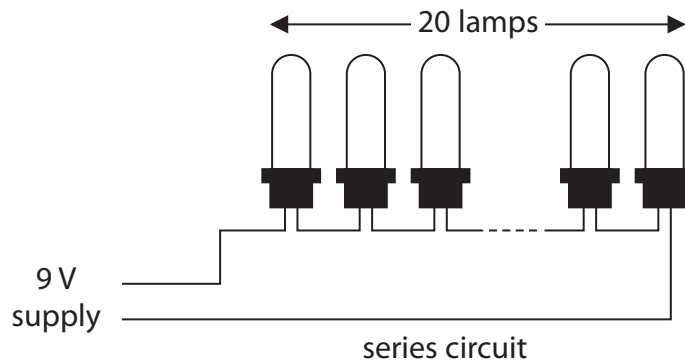

(a) (i) What is the voltage across each lamp in the series circuit?

(1)

(ii) Each lamp has a power of 1.5 W.

State the equation linking power, current and voltage.

(1)

(iii) Show that the current in the circuit is about 3 A.

(2)

(b) (i) The lamps are on for 7 hours a day for 5 days.

Calculate the total energy transferred during this time.

(3)

energy transferred = J

(ii) Describe the energy changes that take place in the lamps when they are connected to the power supply.

(2)

.....

.....

.....

.....

(Total for Question 2 = 9 marks)

3 A ball has a mass of 0.25 kg.

A student holds the ball 1.75 m above the ground.

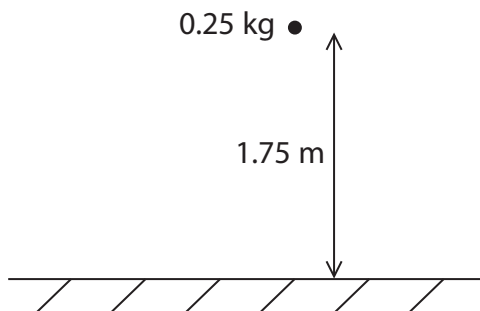

(a) (i) State the equation linking gravitational potential energy (GPE), mass, g and height. (1)

(ii) Calculate the gravitational potential energy of the ball. (2)

GPE = J

(b) The student lets the ball fall.

State the value of the kinetic energy (KE) of the ball just before it hits the ground.

Assume that there is no air resistance.

(1)

KE = J

(c) Another ball with the same mass has a kinetic energy of 3.1 J.

(i) State the equation linking kinetic energy, mass and speed.

(1)

(ii) Calculate the speed of the ball.

(3)

speed = m/s

(Total for Question 3 = 8 marks)

4 A student feels cold at night and decides to sleep under a thick woollen blanket.

(a) Explain how the woollen blanket helps to keep the student warm.

(4)

.....

.....

.....

.....

.....

.....

.....

.....

.....

.....

.....

(b) The student says



I think that I can use shiny aluminium foil instead to keep myself warm.

Do you agree with the student?

Explain why.

(1)

.....

.....

.....

.....

(Total for Question 4 = 5 marks)

5 The photograph shows a small aeroplane, of mass 600 kg.



This aeroplane has an electric motor powered by fuel cells.

Fuel cells use hydrogen gas and provide an electric current.

(a) When the aeroplane is working, the energy changes are

(1)

- A chemical → electrical → kinetic
- B electrical → chemical → kinetic
- C electrical → kinetic → chemical
- D kinetic → chemical → electrical

(b) The velocity of the aeroplane is 28 m/s.

(i) State the equation linking kinetic energy, mass and velocity.

(1)

(ii) Calculate the kinetic energy of the aeroplane.

(2)

Kinetic energy = J

- (c) The aeroplane takes off and climbs to a height of 1000 m.
- (i) State the equation linking gravitational potential energy (GPE), mass, g and height. (1)

- (ii) Calculate the gravitational potential energy gained by the aeroplane. (2)

GPE of the aeroplane = J

- (iii) The fuel cells provide a maximum total power of 24 kW. The aeroplane also carries a large rechargeable battery.
- Show, by calculation, that the aeroplane needs this extra source of power to climb to 1000 m in 3 minutes. (2)

- (iv) The aeroplane uses fuel cells connected together in series in a 'stack'.
- The voltage of each fuel cell is 0.6 V. The maximum current in each fuel cell is 30 A.
- Show that there must be more than 1300 fuel cells in the stack. (2)

- 6 (a) A student investigates the energy transfers in a small generator.

She connects the generator to a circuit that includes a lamp.

She hangs a mass from a string wound around the axle.

The lamp lights as the mass falls to the ground.

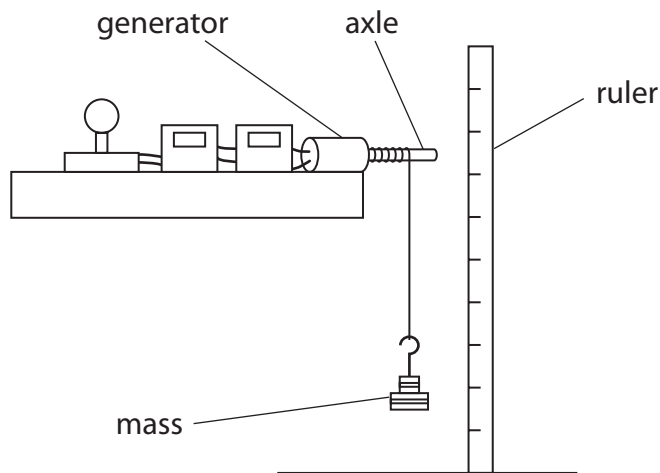

The table shows the student's results.

height that mass falls	0.61 m
mass	2.75 kg
time taken for mass to fall	1.3 s
average current in the lamp	0.46 A
average voltage across the lamp	12.7 V

- (i) State the equation linking gravitational potential energy, mass, g and height.

(1)

- (ii) Calculate the gravitational potential energy, GPE, lost by the mass.

(2)

GPE = J

(iii) Explain why only some of the gravitational potential energy of the mass is transferred to the lamp.

(2)

.....

.....

.....

.....

(iv) Calculate the energy transferred to the lamp.

(2)

energy transferred = J

(b) Water from a reservoir can be used to generate electricity on a large scale.

Describe the energy transfers involved in this process.

(3)

.....

.....

.....

.....

.....

.....

.....

.....

.....

.....

(Total for Question 6 = 10 marks)

7 The diagram shows typical values for the percentage energy losses from a house.

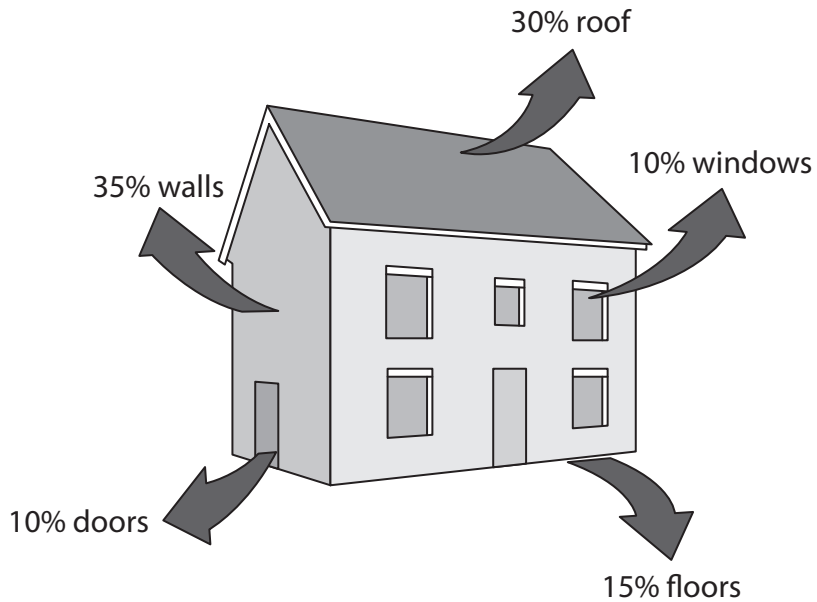

(a) Most energy is lost through

(1)

- A the floors
- B the roof
- C the walls
- D the windows

(b) The total percentage energy loss from the roof and the windows is

(1)

- A 10%
- B 20%
- C 30%
- D 40%

(c) Insulation is used to reduce energy losses from houses.

Insulating material often consists of fibres with air between them.

The diagram shows a section through some insulating material.

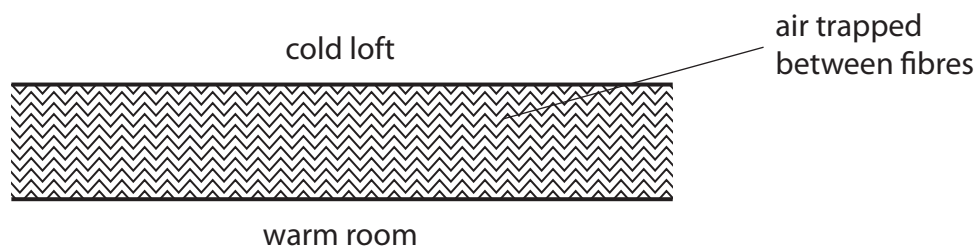

(i) Explain how this type of insulation reduces energy loss by **conduction**.

(2)

.....

.....

.....

.....

.....

(ii) Explain how this type of insulation reduces energy loss by **convection**.

(2)

.....

.....

.....

.....

.....

(Total for Question 7 = 6 marks)

8 A student investigates the efficiency of an electric motor.

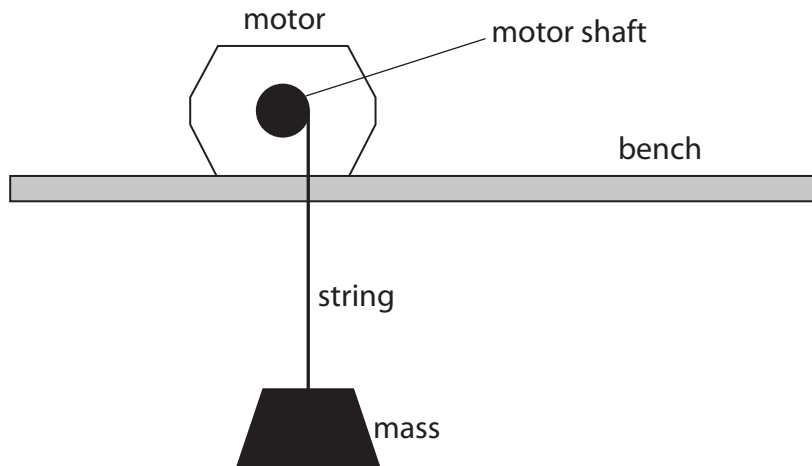

She uses the motor to lift a mass.

The table shows her measurements.

Current in motor	1.3 A
Voltage across motor	10.3 V
Time taken to lift mass	4.7 s
Force needed to lift mass	20 N
Distance the mass was lifted	0.85 m

(a) Calculate the electrical energy supplied to the motor during this time.

(2)

energy supplied = J

(b) (i) State the equation linking work done, force and distance moved. (1)

(ii) Calculate the work done on the mass. (2)

work done = J

(iii) State the useful energy transferred to the mass. (1)

(c) (i) State the equation linking efficiency, useful energy output and total energy input. (1)

(ii) Calculate the efficiency of the motor. (2)

efficiency =

(Total for Question 8 = 9 marks)