

# Density and Pressure

## Question paper 2

<b>Level</b>	IGCSE(9-1)
<b>Subject</b>	Physics
<b>Exam Board</b>	Edexcel IGCSE
<b>Module</b>	Double Award (Paper 1P)
<b>Topic</b>	Solids, Liquids and Gases
<b>Sub-Topic</b>	Density and Pressure
<b>Booklet</b>	Question paper 2

**Time Allowed:** 50 minutes

**Score:** /41

**Percentage:** /100

**Grade Boundaries:**

A*	A	B	C	D	E	U
>85%	'75%	70%	60%	55%	50%	<50%

1 A student wants to calculate the pressure he exerts on the floor when he stands on one foot. He records these measurements.

My weight	650 .....
Area of the floor in contact with my foot	270 cm <sup>2</sup>

(a) (i) Complete the table by adding the unit for weight. (1)

(ii) Which piece of equipment should the student use to measure his weight? (1)

.....

(b) Suggest how the student measured the area of the floor in contact with his foot. (3)

.....  
.....  
.....  
.....  
.....  
.....

(c) (i) State the equation linking pressure, force and area. (1)

(ii) Calculate the pressure that the student’s foot exerts on the floor. (2)

pressure = ..... N/cm<sup>2</sup>

**(Total for Question 1 = 8 marks)**

2 John Leslie was a scientist who investigated heat and thermometers.

He experimented with a hollow metal cube. The cube had different surfaces on each side and was filled with boiling water.

(a) A student uses a modern version of Leslie’s cube to investigate how the surface of a hot object affects the radiation emitted.

She uses a cube with four different vertical surfaces.

She fills the cube with boiling water so that the temperature of each surface is the same.

She uses the radiation sensor to measure the radiation emitted from each surface.

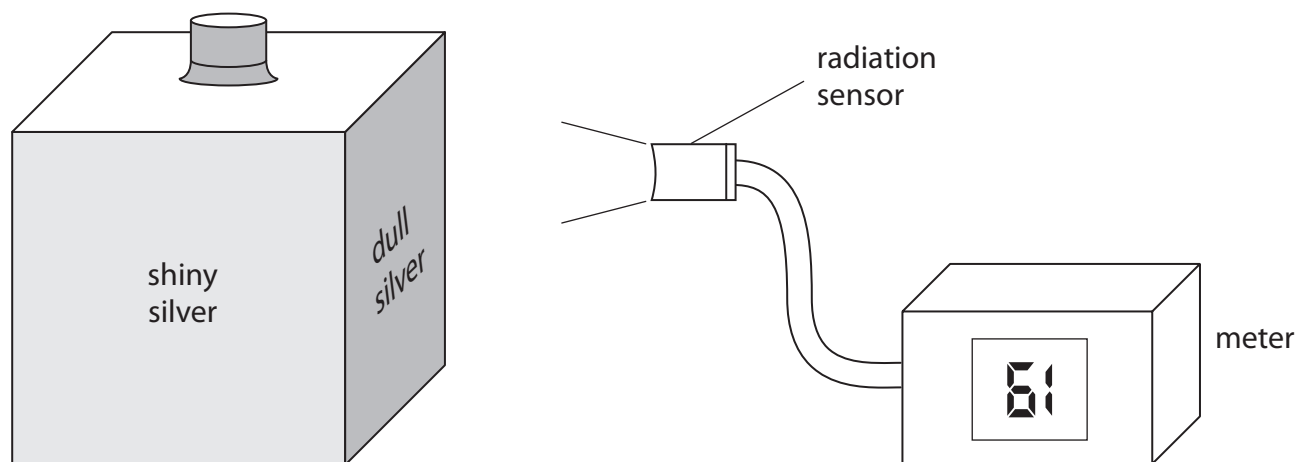

(i) The student’s results are shown below.

Draw a line linking each surface colour with its correct meter reading.

One has been done for you.

(2)

surface colour	meter reading
shiny black	87
dull black	61
dull silver	70
shiny silver	47

(ii) The temperature of each surface is the same, but the radiation sensor gives a different reading for each surface.

What can you conclude from this?

(1)

.....

.....

(b) John Leslie also invented a differential thermometer.

The diagram shows this thermometer.

The bulbs are filled with air and are connected by a tube which contains liquid.

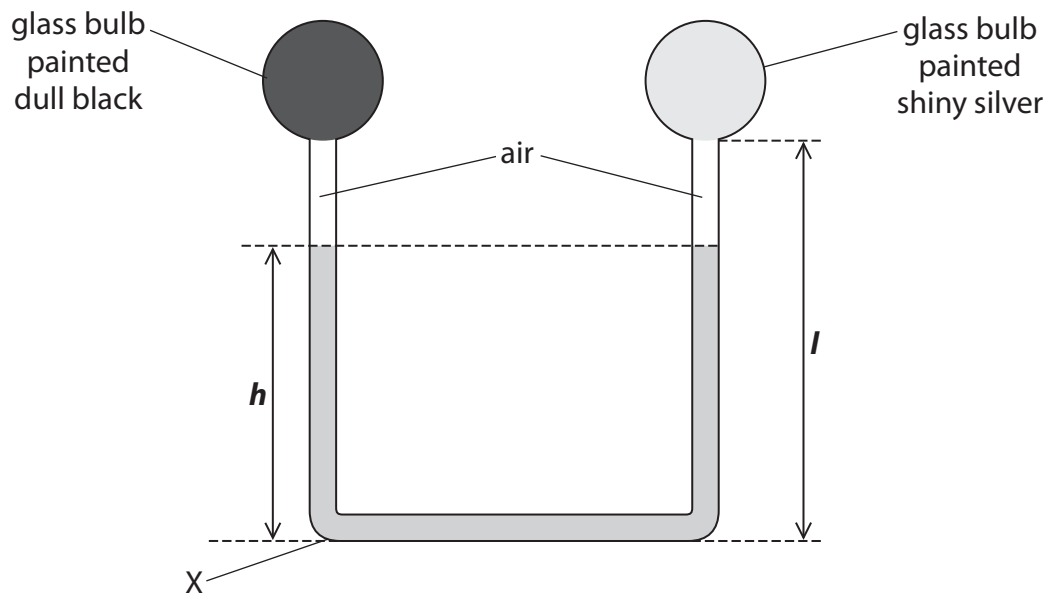

(i) State the equation linking pressure difference, height, density and  $g$ .

(1)

(ii) The density of the liquid is  $1260 \text{ kg/m}^3$ .

Calculate the pressure due to the liquid at  $X$  when the height,  $h$ , of the column of liquid is  $0.25 \text{ m}$ .

Give the unit.

(3)

pressure = ..... unit .....

(iii) The student places the differential thermometer in bright sunlight for a few minutes.

She observes that the liquid level

- falls on the side of the dull black bulb making  $h$  lower
- rises on the side of the shiny silver bulb

Use ideas about heat transfer and particle theory to explain these observations.

(3)

.....

.....

.....

.....

.....

.....

.....

.....

.....

.....

.....

(iv) Explain what would happen to the levels of the liquid if the student repeated the experiment with a denser liquid in the thermometer.

(2)

.....

.....

.....

.....

.....

.....

- (v) Two students discuss the effect of changing the length,  $l$ , of the tube on both sides, while keeping the total volume of liquid constant.



If the length of the tube is increased, the thermometer can measure higher temperatures.



Changing the length of the tube will not make any difference to the range of temperatures that the thermometer can measure.

Explain which of these ideas is correct.

(2)

.....

.....

.....

.....

**(Total for Question 2 = 14 marks)**

3 The object shown in the photograph is an old, brass mass.

It is marked 500 g.



(a) A student puts the mass on an electronic balance.

The electronic balance reading is 498.2 g.

The student concludes:



"I think that the electronic balance is **not** working properly."

Evaluate this conclusion.

(2)

.....

.....

.....

.....

.....

.....

(b) The student wants to find the density of the old, brass mass.

First he obtains a correct value for the mass.

What else must he do to find the density?

(3)

.....

.....

.....

.....

.....

.....

.....

.....

.....

.....

.....

.....

.....

.....

.....

.....

.....

.....

.....

.....

.....

.....

**(Total for Question 3 = 5 marks)**



4 The photograph shows two containers that store rainwater.

The containers have taps that are joined by a pipe.

The taps are closed.

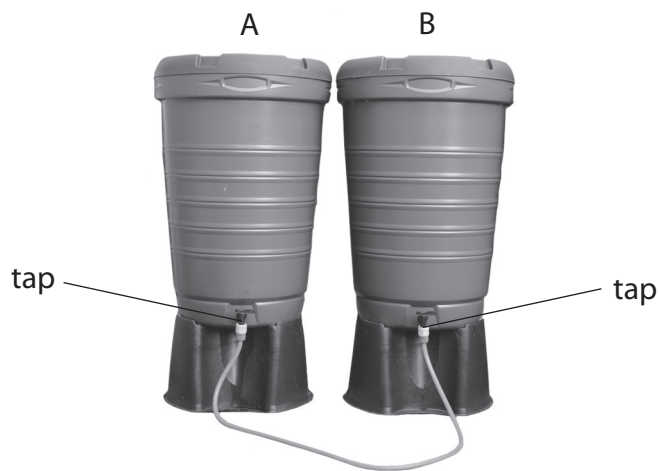

The diagram shows the water levels inside the containers.

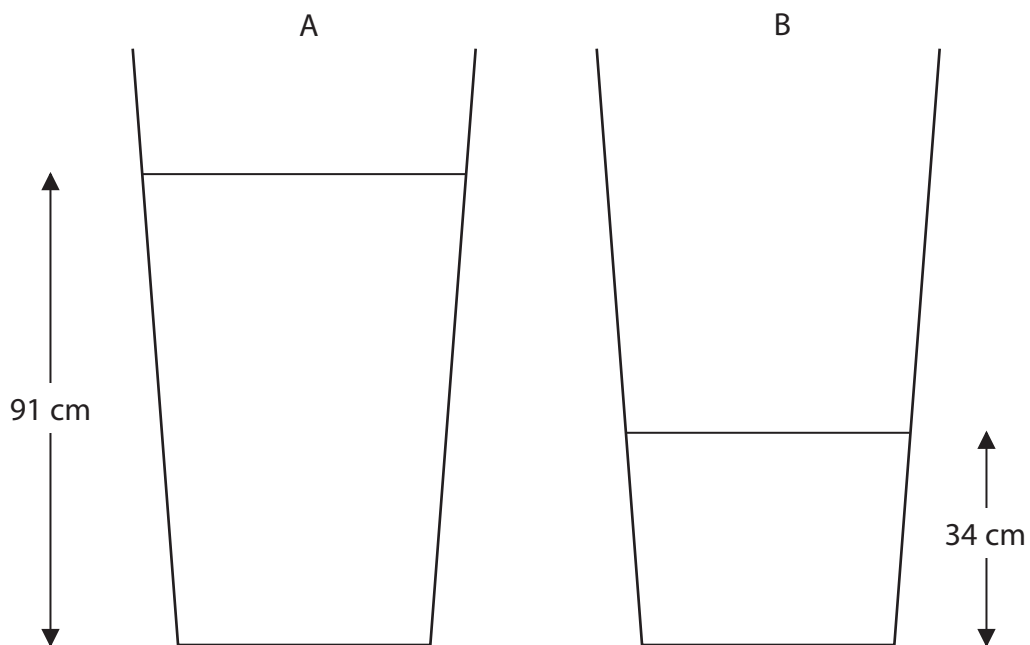

(a) The density of water is  $1000 \text{ kg/m}^3$ .

(i) State the equation linking pressure difference, height, density and  $g$ .

(1)

(ii) Calculate the pressure that the water causes at the base of container A.

(2)

pressure = ..... Pa

(b) When the taps are opened, water flows in the pipe for some time. The diagram shows the final water level in container A.

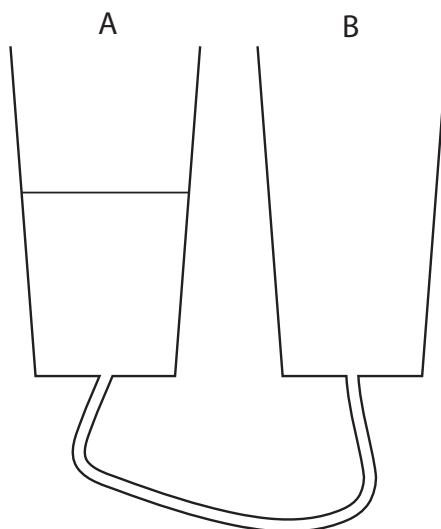

(i) Complete the diagram to show the final water level in container B.

(1)

(ii) Explain why the water starts to flow and then stops.

(3)

.....

.....

.....

.....

.....

.....

.....

.....

.....

**(Total for Question 4 = 7 marks)**

5 A spray-can contains gas particles that are constantly moving.

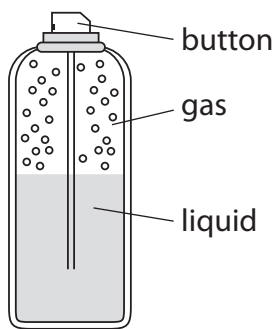

(a) (i) How do the gas particles produce a pressure on the walls of the spray-can?

(3)

.....

.....

.....

.....

.....

.....

(ii) A student presses the button and some liquid leaves the can.

The student concludes



I think that the gas pressure in the spray-can decreases as the liquid leaves the can.

Evaluate this conclusion.

(3)

.....

.....

.....

.....

.....

.....

(b) What happens to the average speed of the gas particles when the spray-can is warmed by the sun on a hot day?

(1)

.....

.....

**(Total for Question 5 = 7 marks)**