

Movement and position

Question paper 2

Level	IGCSE(9-1)
Subject	Physics
Exam Board	Edexcel IGCSE
Module	Double Award (Paper 1P)
Topic	Forces and motion
Sub-Topic	Movement and position
Booklet	Question paper 2

Time Allowed: 68 minutes

Score: /56

Percentage: /100

Grade Boundaries:

A*	A	B	C	D	E	U
>85%	'75%	70%	60%	55%	50%	<50%

(c) The diagram shows the skydiver falling at a constant velocity.

Add **two** labelled arrows to the diagram to represent the forces acting on the skydiver. (3)



(d) The skydiver opens his parachute after 40 s.

Continue the line on the graph to show how the skydiver's vertical velocity changes and reaches terminal velocity. (2)

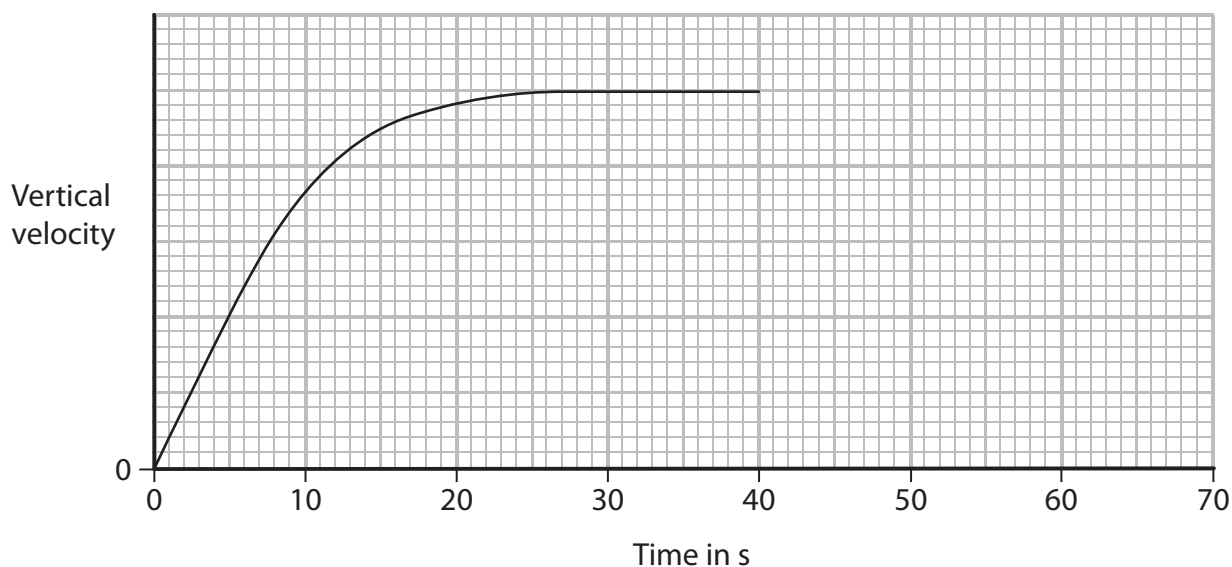

(Total for Question 1 = 12 marks)

2 The Apollo 15 mission landed on the Moon in 1971.

The astronaut David Scott dropped a hammer and a feather.

They were released from rest at the same time and from the same height.

The hammer and the feather landed at the same time.

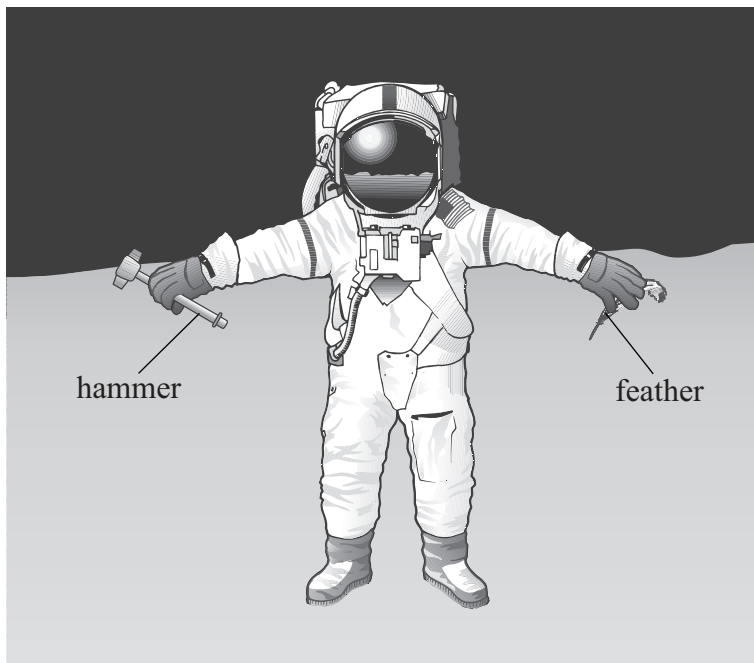

(a) The graph shows how the velocity of the hammer changed with time.

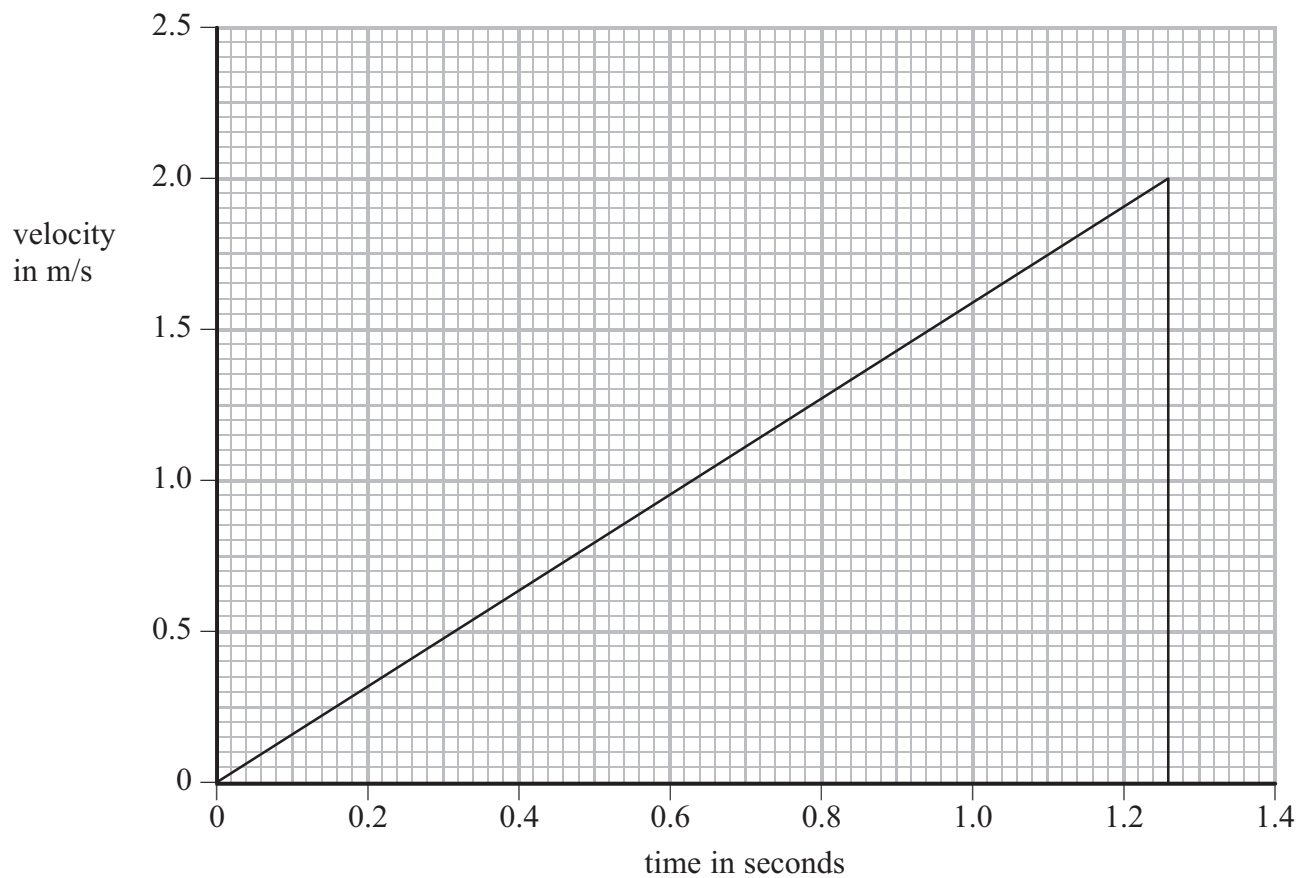

(i) Use the graph to calculate the acceleration due to gravity on the Moon.

Give the unit.

(3)

Acceleration = Unit

(ii) Use the graph to calculate the height the hammer was dropped from.

(2)

Height = m

(b) The gravitational field strength is smaller on the Moon than on the Earth.

Suggest why.

(1)

.....
.....

- 3 The graph shows the minimum stopping distances, in metres, for a car travelling at different speeds on a dry road.

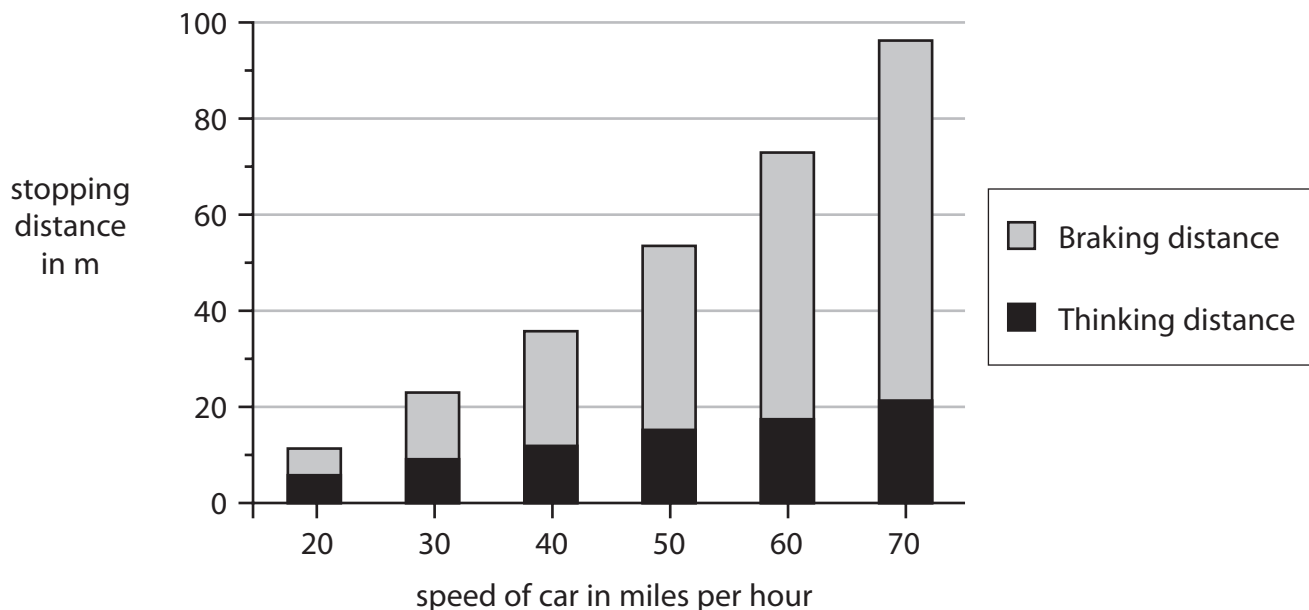

- (a) Complete the equation to show the link between stopping distance, thinking distance and braking distance.

(1)

Stopping distance =

- (b) Describe the patterns shown in the graph.

(2)

.....

- (c) Use the graph to estimate the stopping distance for a car travelling at 35 miles per hour.

(1)

(d) To find the minimum stopping distance, several different cars were tested.

Suggest how the data from the different cars should be used to give the values in the graph.

(1)

.....

.....

.....

(e) The tests were carried out on a dry road.

If the road is icy, describe and explain what change there would be, if any, to

(i) the thinking distance

(2)

.....

.....

.....

(ii) the braking distance

(2)

.....

.....

.....

(Total for Question 3 = 9 marks)

4 The graph shows how the velocity of an aircraft changes as it accelerates along a runway.

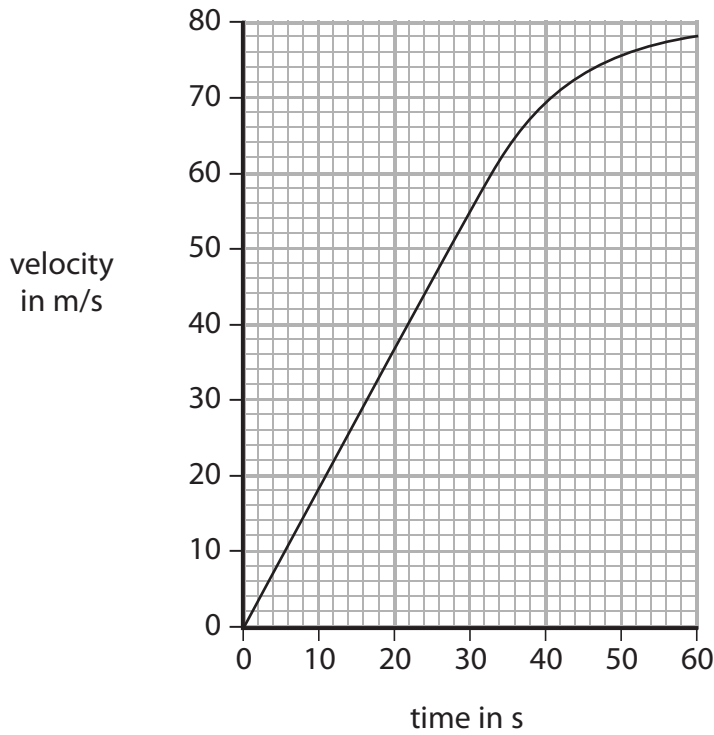

(a) Use the graph to find the average acceleration of the aircraft. (3)

Acceleration = m/s²

(b) Explain why the acceleration is not constant, even though the engines produce a constant force. (3)

.....

.....

.....

.....

.....

.....

.....

.....

(Total for Question 4 = 6 marks)

5 The diagram shows an air track that can be used to investigate motion.

Air comes out through a series of small holes in the air track.

A small glider floats on a cushion of air.

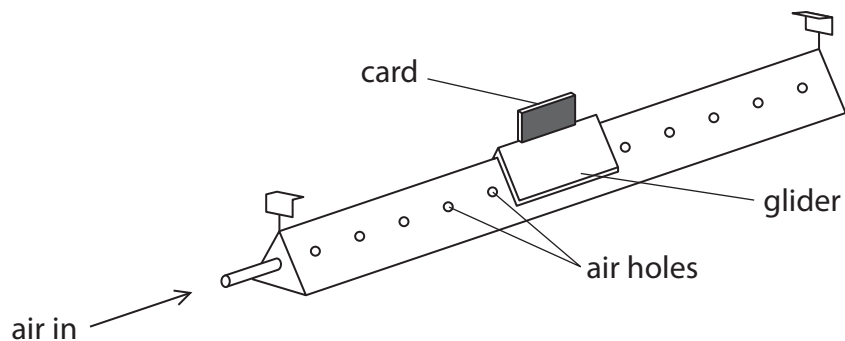

(a) (i) The diagram below shows the glider at rest on the air track.

Complete the diagram to show the forces acting on the glider.

Label the forces.

One force arrow has been drawn for you.

(3)

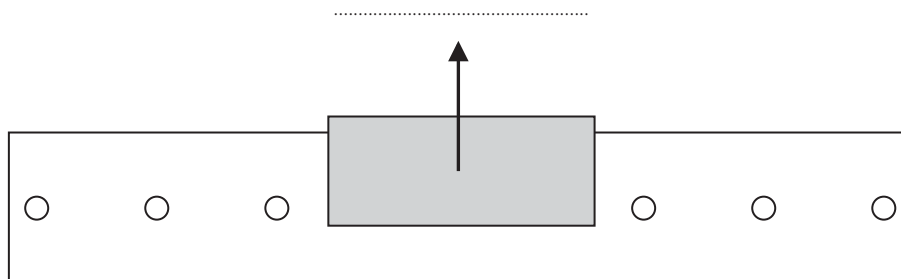

(ii) Explain what effect the cushion of air has on the movement of the glider.

(2)

.....

.....

.....

.....

- (b) Two light gates connected to a data logger are placed above the air track so that the card will pass through them.

The glider moves at a constant speed to the right.

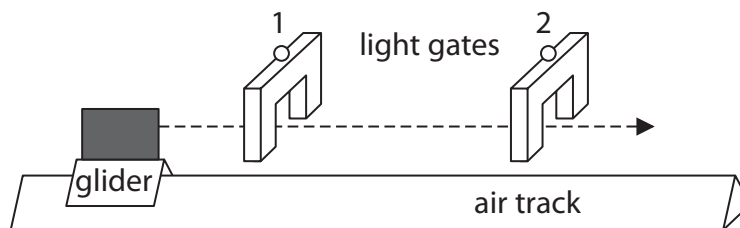

The length of the card is 8.3 cm.

The card takes 314 ms to pass through the first light gate.

- (i) State the relationship between average speed, distance moved and time taken. (1)

- (ii) Calculate the average speed of the card as it passes through the first light gate. (2)

average speed = cm/s

- (iii) State the time taken for the card to pass through the second light gate. (1)

time taken =ms

(Total for Question 5 = 9 marks)

6 The photograph shows a type of rollercoaster.

The car is launched from point **A** in the photograph, accelerates to point **B** and then rises over point **C**.

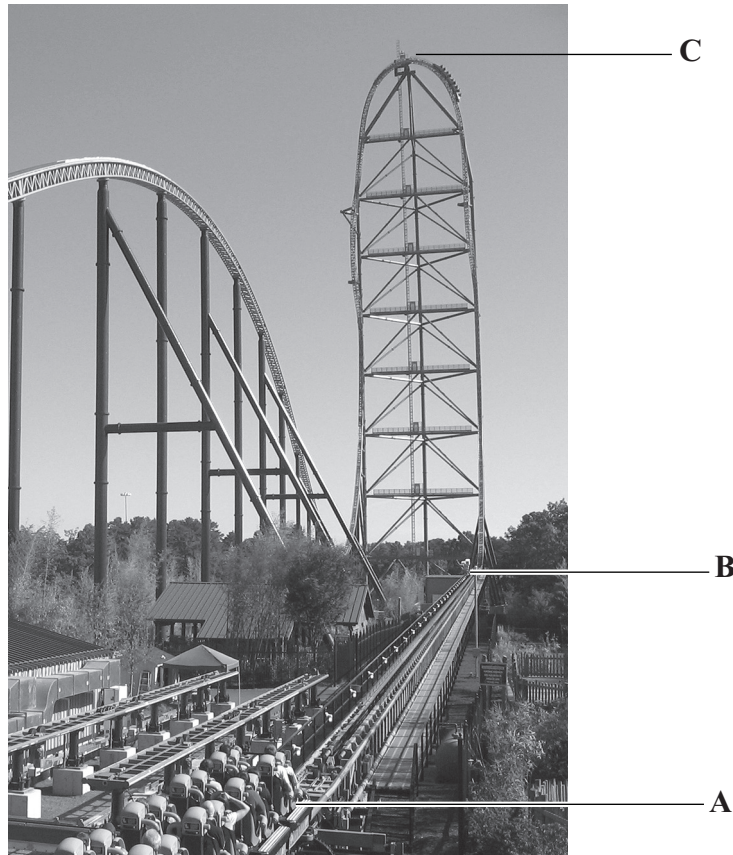

(a) Each loaded car has a mass of 2000 kg.

C is 128 m above **B**.

(i) State the equation linking gravitational potential energy, mass, height and gravitational field strength.

(1)

(ii) Show that the gravitational potential energy gained by the car when it rises from **B** to **C** is about 2.6 MJ.

(2)

(b) The car gains kinetic energy when work is done on it by the launching system between **A** and **B**.

Assume there are no energy losses.

(i) State the minimum kinetic energy that the car must have at **B** for it to reach **C**. (1)

.....

(ii) How is the kinetic energy gained related to the work done? (1)

.....

(iii) Write down the equation linking work done, force and distance. (1)

(iv) The launching system provides a force of 32 kN.

Calculate the minimum length of track needed between **A** and **B** for the car to reach **C**. (2)

Length of track = m

(c) Sometimes the car does not reach **C**, but rolls backwards to the start.

This can happen when it becomes windy or the track becomes wet.

Explain why these conditions could cause the car to stop before it reaches **C**. (2)

.....
.....
.....
.....

(Total for Question 6 = 10 marks)